



# USER MANUAL



## T-540 PLUS SE TELEPHONE PLUS DIGITAL SYSTEM



## INTRODUCTION

---

First of all, we thank and congratulate you for purchasing this product manufactured by Golmar.

Our commitment to achieving the satisfaction of customers like you is manifested through our ISO-9001 certification and the manufacture of products like the one you have just purchased.

Its advanced technology and strict quality control will ensure that customers and users enjoy the numerous features that this device offers. To get the most out of them and ensure proper operation from day one, we recommend that you read this instruction manual.

## CONTENTS

---

Introduction.....	2
Contents.....	2
Safety precautions.....	2
Characteristics.....	3
Functioning of the telephone.....	3
Description of the telephone.....	4
Description.....	4
Status LED.....	4
Connection terminals.....	4
Function buttons.....	5
SW1 DIP switch.....	5
Fixing the telephone.....	6
Programming of the telephone.....	7
Quick programming of the telephone.....	8
Advanced programming (telephone functions).....	8
Menu 1.....	8
-Changing the ringtone melody.....	8
-Activating / deactivating the doctor mode function.....	8
Menu 2.....	9
-Intercom with Plus telephones / monitors.....	9
-Changing the function of button <b>B</b> .....	9
-Changing the function of button <b>C</b> .....	9
Menu 3.....	9
-Repeating the ringtones.....	9
-Adjusting the “door panel communication time”.....	9
-Adjusting the “door panel call time”.....	10
Menu 4.....	10
-Setting all of the telephone's advanced programming options to the “default value”.....	10
Optional connections.....	11
-Activating auxiliary devices.....	11
-Auxiliary button input for activating the door panel door release.....	11
-Intercom within the same apartment.....	12
-Button for receiving calls from the apartment front door.....	12
-Cleaning the telephone.....	13
Wiring diagram.....	14
Notes.....	15

## SAFETY PRECAUTIONS

---

- Do not overtighten the telephone fixing screws.
- **Always disconnect the power supply** before making modifications to the device.
- The fitting and handling of these devices must be carried out by **authorised personnel**.
- All of the wiring must run at least **40cm away from any other wiring**.
- Install the telephone in a dry protected location free from the risk of dripping or splashing water.
- Do not place in humid, dusty or smoky locations, or near sources of heat.
- Before connecting the device to the mains, check the connections between the door panel, power supply and telephones.
- Always follow the instructions contained in this manual.









## CHARACTERISTICS

---

- Telephone for Plus installation.
- Telephone with 4 common wire installation.
- Function and advanced programming access buttons (to customise telephone functions).
- Totally private conversation.
- Auto switch-on function.
- "Doctor mode" function (automatic door opening, see p. 8).
- Intercom between two devices in the same apartment.
- Apartment front door call input.
- Call volume adjustment: maximum, medium, minimum and no volume "night mode", (see p. 5 "function buttons").
- Door panel exterior door release button input.
- Output to auxiliary call repeater.
- Call to main and secondary guard unit.
- Panic call to guard units.
- Different ringtones to identify call origin: Door panel, guard unit, intercom and interior door of apartment "HZ".
- Activation of auxiliary functions: courtesy lights, second lock release, etc.
- DIP switches for setting the telephone address, "call code" and master/slave (quick programming mode).
- Door release button.
- Telephone status LED.

## SYSTEM OPERATION

---

- To make a call, the visitor presses the button for the apartment, a number of audible tones indicate that the call is being made and LED  on the door panel illuminates. At this moment, the apartment's telephone (monitor) receives the call. If the visitor presses the button for another apartment by mistake, the call can be cancelled by pressing the button for the correct apartment.
- In systems with several access doors, the other door panel(s) automatically disconnects. If another visitor attempts to call, a number of telephone tones will indicate that the channel is busy and LED  on the door panel will illuminate.
- General entrance door panels (mode EL501): If the call is being made from the general entrance door panel, the interior door panel of the building being called and other possible general entrance door panels automatically disconnect. If another visitor attempts to call from either a busy interior door panel, a number of telephone tones will indicate that the channel is busy and LED  of the door panel will illuminate, or from another general entrance door panel, a number of telephone tones will indicate that the channel is busy and LED  of the general entrance door panel will blink for 3 seconds. The door panels of the other interior buildings will remain free to be used.
- General entrance door panels (mode EL501): If the call is made from an interior door panel, the other interior door panels will remain free to be used. It is only possible to make calls to interior buildings from the general entrance door panels when their door panels are not in use. If an attempt is made to make a call to a busy interior door panel, a number of telephone tones will indicate that the channel is busy and LED  of the general entrance door panel will blink for 3 seconds.
- The call lasts for 45 seconds and the status LED of the master telephone will illuminate (green). If the call is not answered within 45 seconds, the master telephone's status LED will illuminate (red), LED  on the door panel will turn off and the channel will be free.
- To establish communication, lift the handset of the telephone (monitor), and the telephone's status LED (green) and the door panel's LED  will illuminate.
- The communication will last for one and a half minutes or until the handset is replaced. After the communication, the telephone's status LED will illuminate (red), the door panel's LED  will turn off and the channel will be free.
- To open the door, press the door release button during the call or communication processes: one press will activate the door release for 3 seconds and LED  will also illuminate for 3 seconds.
- A description of the function buttons can be found on p. 5.

DESCRIPTION OF THE TELEPHONES

Description of the T-540 Plus SE telephone



- a. Telephone handset.
- b. Speaker grille.
- c. Microphone hole.
- d. Suction hole.
- e. Telephone cord connectors.
- f. Function / programming buttons.
- g. Telephone status LED:
  - Standby: LED illuminated red.
  - Call: LED illuminated green (master telephone).
  - Communication: LED illuminated green.
  - Night mode: LED blinking red.
  - Doctor mode: LED blinking green.
- h. Hook switch.

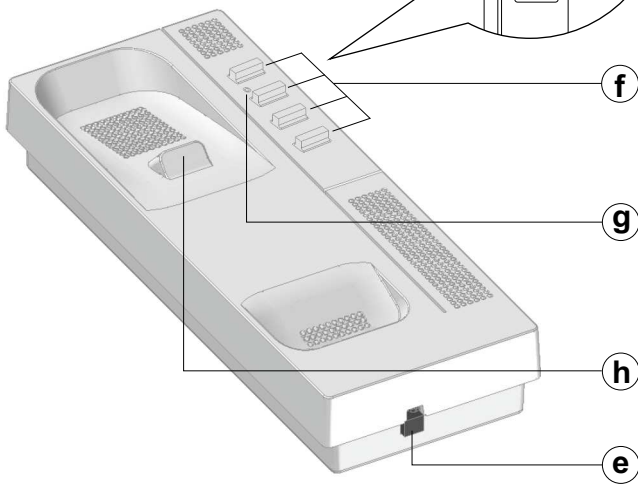
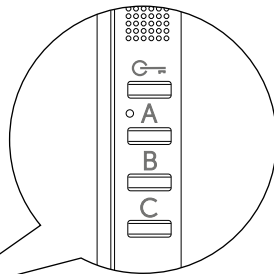

Description of the connection terminals:

+	-	A	D	AP+	-	HZ-	SA	+	Int	A1
---	---	---	---	-----	---	-----	----	---	-----	----

- +, - : Positive, negative (18Vdc power supply).
- A, D : Audio, digital communication.
- AP+ : Auxiliary door release button input.
- HZ- : Door bell button input.
- SA : Output (negative) auxiliary call repeater (max. consumption 250mA).
- INT : Intercom function.
- A1 : Output (negative) auxiliary device activation (max. consumption 50mA)

DESCRIPTION OF THE TELEPHONES

**Function button:**

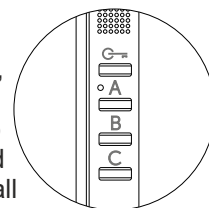

**A** One short press for 1 second, with the telephone in standby and the handset on the hook, activates ringtone volume mode, with a tone indicating the volume selected. Then each 1 second press (before 5 seconds elapse) selects a ringtone volume level and so on (in carousel mode) with the following selections (maximum, medium, minimum and no volume “night mode”. Note: The “night mode” status LED blinks red). During a call process, the telephone will emit a ringtone and exit volume mode. Regardless of the volume selected, the “apartment interior door call” ringtone will always sound at the highest level.

One long press for 3 seconds, with the telephone in standby and the handset on or off the hook, turns the telephone on or off. After any resetting of the telephone and for the following 45 seconds, no operation with it can be performed.

(\*) **B** With the handset off the hook, the intercom (in the same apartment) is activated. One long press until a confirmation tone can be heard will call all of the telephones in the apartment. To call individual telephones, press the button once to call the “master” telephone, twice to call “slave 1”, 3 times to call “slave 2”, 4 times to call “slave 3” and 5 times to call “slave 4”. This selective intercom call mode is only available with the T540 Plus SE telephone and the Tekna Plus SE monitor. This only functions if no call or communication is in progress.

(\*) **C** Regardless of the position of the handset, the auxiliary device is activated.

 With the handset hung up, a panic call to the guard units configured to receive such calls is made. With the handset off the hook, a normal call can be made to the main guard unit. During call reception and communication processes, it enables the door release to be activated.

(\*) In advanced programming mode (see p. 9), the default functions of function buttons **B** and **C** can be changed with one of the following functions at the same time and per button: (“A1” auxiliary device activation, call to secondary guard unit, auto switch-on or intercom).

**Description of the SW1 DIP switch:**

The SW1 DIP switch is located in the central part of the circuit, accessible by opening the telephone. It enables the telephone to be configured as master/slave and an address to be assigned to it.

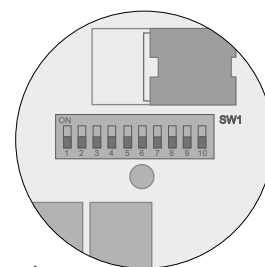

**Important:** This type of programming cannot be performed on a general entrance door panel.

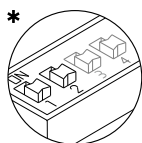

DIP 1 and DIP 2: Configure the telephone as master/slave. DIP 1 and DIP 2 to OFF master, DIP 1 to OFF and DIP 2 to ON slave 1, DIP 1 to ON and DIP 2 to OFF slave 2, DIP 1 and DIP 2 to ON slave 3.

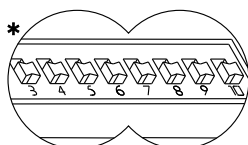

DIP 3 to DIP 10: To configure the telephone address. The switches set to OFF have a zero value. The values of the switches set to ON are shown in the table below. The telephone code is the sum of the values of the switches set to ON.

Switch number:	3	4	5	6	7	8	9	10
Value when ON:	128	64	32	16	8	4	2	1

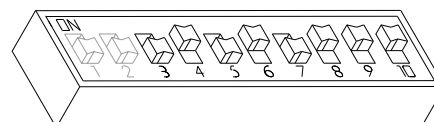

Example: 0+ 64+0+16+0+4+2+1=87

\*Factory setting

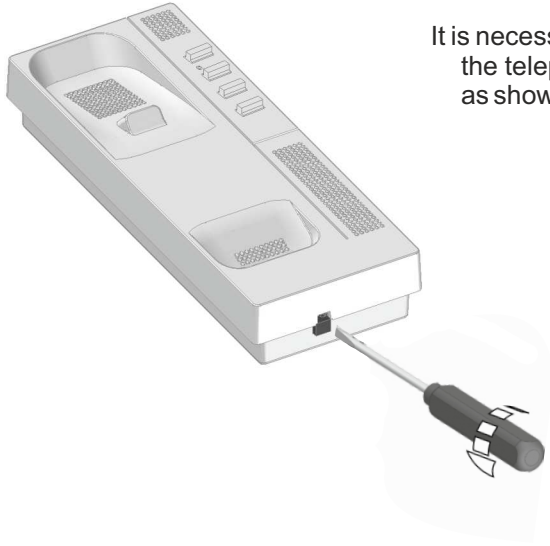
**INSTALLING THE TELEPHONES*****Fixing the telephone to the wall:***

It is necessary to open the telephone for wiring and fixing purposes. To open the telephone, insert a flat screwdriver into the slots and gently pry open as shown in the drawing.

Avoid dusty or smoky environments or locations near sources of heat. The telephone can be fixed to an electrical embedding box or directly to the wall. To secure directly to the wall, drill two 6mm holes at the specified positions using 6mm wall plugs and Ø3.5 x 25mm screws.

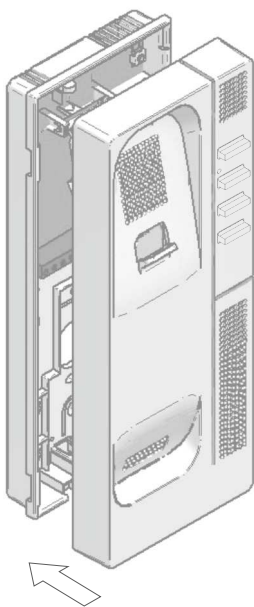
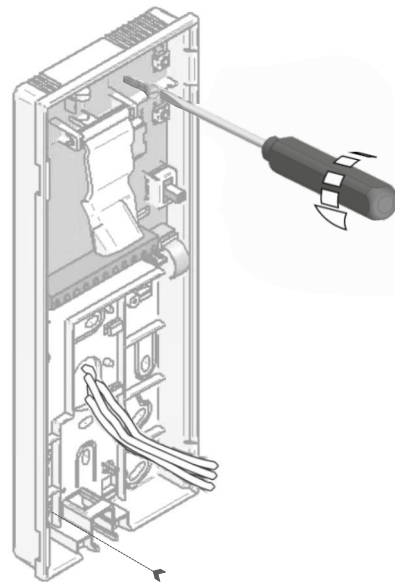

Pass the cables through the cable holes and connect them to the connector as per the wiring diagrams. Close the telephone as shown in the drawing. Once the telephone is closed, connect the handset using the telephone cord and place it on the hook.

**PROGRAMMING THE TELEPHONES**

***Programming T-540 Plus SE telephones:***

Locate the SW2 DIP switch situated on the top left-hand side of the back of the EL632/PLUS module and set number 2 to ON. The door panel will reproduce a sound to advise that the system has entered into programming mode.

In systems with more than one door panel, only perform this procedure on the main door panel of each building.

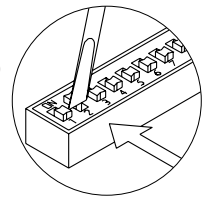

**Important:** To perform this programming, the telephone's SW1 DIP switch should be set to **OFF**.

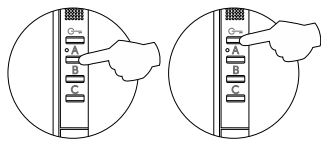

Switch off the telephone to be programmed.  
Once switched off, press the door release button.

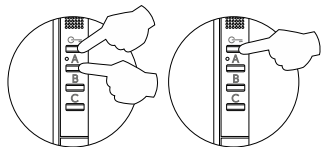

While keeping the door release button pressed, switch on the telephone.

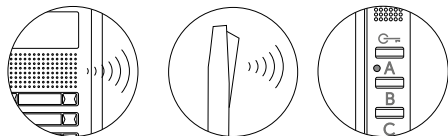

To show that the system is ready for programming, the door panel and the telephone handset will emit a number of tones (the LED on the telephone will illuminate red), enabling the door release button to be released. To establish audio communication with the door panel, lift the handset.



Press the button of the door panel that will call this telephone.  
At this moment, the door panel and handset will emit a number of tones (the LED on the telephone will blink red).

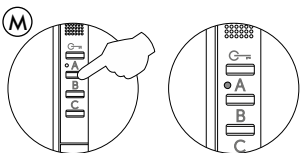

To programme the telephone as *Master*, press button **A** for 3 seconds (the telephone's LED will illuminate red).

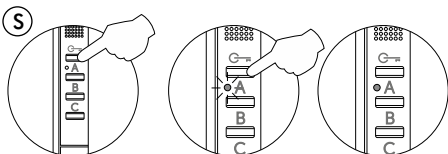

To programme it as *Slave 1*, press button **G** once, and the status LED will blink (green) once. Continue successively to *Slave 4*, pressing button **G** four times, and the status LED will blink (green) four times.

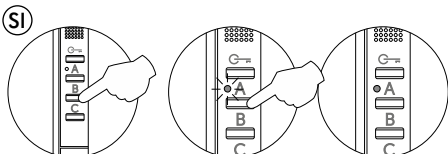

To programme the telephone as *Slave + Intercom*, press button **B** and the LED will blink (green) once. Then press button **A** for 3 seconds (the telephone's LED will illuminate red).

**Each apartment must only have one master unit;** if there are parallel units, either telephones or monitors, they must be configured as slaves.

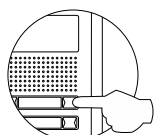

Make a call to check that the telephone has been successfully programmed. Programme the other telephones in the same way.  
Once the programming has finished, set the programming switch to OFF. If this is not done, the door panel will emit tones to indicate that the system is still in programming mode.



**PROGRAMMING THE TELEPHONES**

**Description of the SW1 DIP switch:**

The SW1 DIP switch is located in the central part of the circuit, accessible by opening the telephone. It enables the telephone to be configured as master/slave and an address to be assigned to it.

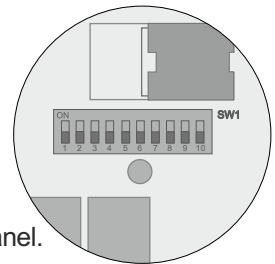

**Important:** This type of programming cannot be performed on a general entrance door panel.

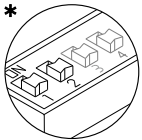

DIP 1 and DIP 2: Configure the telephone as master/slave. DIP 1 and DIP 2 to OFF master, DIP 1 to OFF and DIP 2 to ON slave 1, DIP 1 to ON and DIP 2 to OFF slave 2, DIP 1 and DIP 2 to ON slave 3.

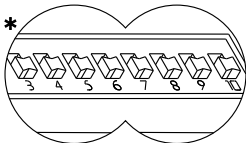

DIP 3 to DIP 10: To configure the telephone address. The switches set to OFF have a zero value. The values of the switches set to ON are shown in the table below. The telephone code is the sum of the values of the switches set to ON.

Switch number:	3	4	5	6	7	8	9	10
Value when ON:	128	64	32	16	8	4	2	1

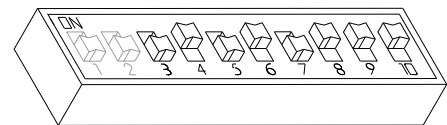

Example:  $0 + 64 + 0 + 16 + 0 + 4 + 2 + 1 = 87$

**\*Factory setting**

**Advanced programming of T540 Plus SE telephones:**

Advanced programming enables the telephone's default settings to be changed:

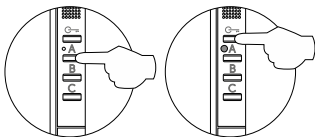

Switch off the telephone to be programmed. Once switched off, press button **G** (for 3 seconds with V.03 and previous or for 5 seconds with V04 and later of the T540 PLUS SE telephone) to enter "Menu 1" of advanced programming, the telephone will emit a number of tones and the LED will illuminate orange.

**Menu 1:**

Then adjust the settings as required:

**- Changing the ringtone melody:**

The telephone has different ringtones to identify the origin of the call. The melodies assigned by default to the ringtones can be selected from among others available on the telephone.

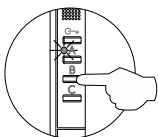

Select the ringtone to be changed: Each press on button **B** selects a ringtone which is indicated with blinks (1 to 4 blinks) of the status LED and in the following order: door panel, guard unit, intercom call and "HZ" apartment interior door call. When the final selection is reached, the following press returns the user to the first selection and the status LED blinks once (carousel mode).

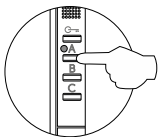

Then select the melody for the ringtone (selected in the previous step) by pressing button **A** until the required "carousel mode" melody is heard.

**- Activating / deactivating the doctor mode function:** Doctor mode not activated (default setting).

The "doctor mode" function enables the door release to be activated automatically 5 seconds after making a call from the door panel without having to establish communication or press door release button **G**. The call ends after 20 seconds and the channel is free.

**(Only the master telephone should be configured with "doctor mode").**

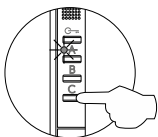

To activate doctor mode: Press button **C**, and the status LED will indicate with 2 blinks that the function is activated or with 1 blink that the function is deactivated.



## PROGRAMMING THE TELEPHONES

Continued from previous page

### - Accessing “Menu 2” or exiting programming mode:

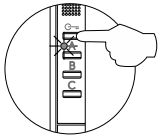

To access “Menu 2”, press button **2**, and the status LED will blink twice.

To exit programming mode, press button **2** for 3 seconds, and the status LED will turn off (see p. 10).

### **Menu 2:**

Then adjust the settings as required:

#### - Intercom with Plus telephones / monitors: Intercom with Plus SE telephones / monitors (default setting).

If an apartment has T-540 Plus telephones, Tekna Plus monitors and T-540 Plus SE telephones, the T-540 Plus SE telephones must be configured in “Intercom with Plus telephones / monitors” mode, as T-540 Plus telephones and Tekna Plus monitors do not allow an intercom call to a particular telephone / monitor in the apartment to be made. That way, when an intercom call is made, all of the monitors / telephones in the apartment will receive the call.

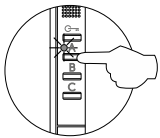

To activate the “Intercom with Plus telephones / monitors” mode: Press button **A**, and the status LED will indicate with 1 blink that the function is in “Intercom with Plus telephones / monitors” mode or with 2 blinks that the function is in “Intercom with Plus SE telephones / monitors” mode.

#### - Changing the function of button **B** : Intercom function (default setting).

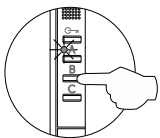

Select the function to assign to button **B** : Each press on button **B** selects a different function which is indicated with blinks (1 to 4 blinks) of the status LED and in the following order: “A1” auxiliary device activation, call to secondary guard unit, auto switch-on and intercom. When the final selection is reached, the following press returns the user to the first selection and the status LED blinks once (carousel mode).

#### - Changing the function of button **C** : “A1” auxiliary device activation function (default setting).

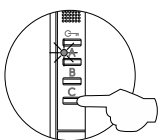

Select the function to assign to button **C** : Each press on button **C** selects a different function which is indicated with blinks (1 to 4 blinks) of the status LED and in the following order: “A1” auxiliary device activation, call to secondary guard unit, auto switch-on and intercom. When the final selection is reached, the following press returns the user to the first selection and the status LED blinks once (carousel mode).

### - Accessing “Menu 3” or exiting programming mode:

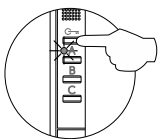

To access “Menu 3”, press button **3**, and the status LED will blink 3 times.

To exit programming mode, press button **3** for 3 seconds, and the status LED will turn off (see p. 10).

### **Menu 3:**

Then adjust the settings as required:

#### - Repeating the ringtones: One repeat (default setting).

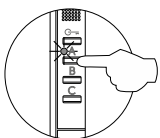

To “repeat the ringtone” on the telephone: Each press on button **A** selects a repeat of the ringtones which is indicated with blinks (1 to 3 blinks) of the status LED and in the following order: 1, 2 or 3 repeats. When the final selection is reached, the following press returns the user to the first selection and the status LED blinks once (carousel mode).

#### - Adjusting the “door panel communication time”: 90 seconds (default setting).

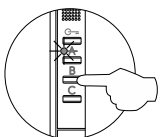

To adjust the “door panel communication time”: Each press on button **B** selects a door panel communication duration (1:60 seconds, 2: 90 seconds, 3): 120 seconds, and 4: 150 seconds), which is indicated with blinks (1 to 4 blinks) of the status LED and in the following order: 1, 2, 3 and 4 repeats. When the final selection is reached, the following press returns the user to the first selection and the status LED blinks once (carousel mode).

## PROGRAMMING THE TELEPHONES

Continued from previous page

### - Adjusting the “door panel call” time: 45 seconds (default setting).

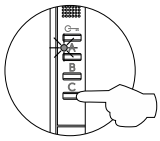

To adjust the “door panel call” time: Each press on button **C** selects a door panel call duration (1: 30 seconds, 2): 45 seconds, 3): 60 seconds, and 4: 90 seconds), which is indicated with blinks (1 to 4 blinks) of the status LED and in the following order: 1, 2, 3 and 4 repeats. When the final selection is reached, the following press returns the user to the first selection and the status LED blinks once (carousel mode).

### - Accessing “Menu 4” or exiting programming mode:

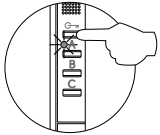

To access “**Menu 4**”, press button **G**, and the status LED will blink 4 times.  
To exit programming mode, press button **G** for 3 seconds, and the status LED will turn off (see p. 10).

### **Menu 4:**

Then adjust the settings as required:

### - Setting all of the telephone's advanced programming options to the “default value”.

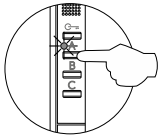

To set to the “default value”: Press button **A**, and the telephone will indicate with two audible tones that all of the options of the telephone's advanced programming (p. 8-10) are set to their default value.

### - Button **B** has no function.

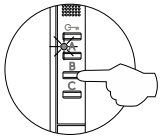

Reserved.

### - Button **C** has no function.

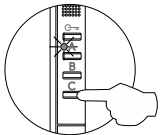

No function.

### - Accessing “Menu 1” or exiting programming mode:

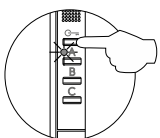

To access “**Menu 1**”, press button **G**, and the status LED will blink once (see p. 8).  
To exit programming mode, press button **G** for 3 seconds, and the status LED will turn off.

### - Turning on the telephone when exiting programming:

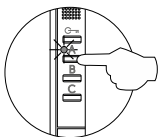

When exiting advanced programming mode, the telephone will be turned off: Press button **A** for 3 seconds to turn the telephone back on. After any resetting of the telephone and for the following 45 seconds, no operation with it can be performed.

OPTIONAL CONNECTIONS

**Auxiliary device activation with T-540 Plus SE telephones:**

Auxiliary device activation requires the use of an SAR-12/24 relay unit. If the feature is shared by all telephones, connect their A1 terminals; if, however, each telephone has its own feature, use an SAR-12/24 relay for each one and do not connect their A1 terminals.

This function is activated when button C is pressed on the telephone at any time and regardless of the position of the handset.

The most common applications are activating the stairway lights and opening a second door.

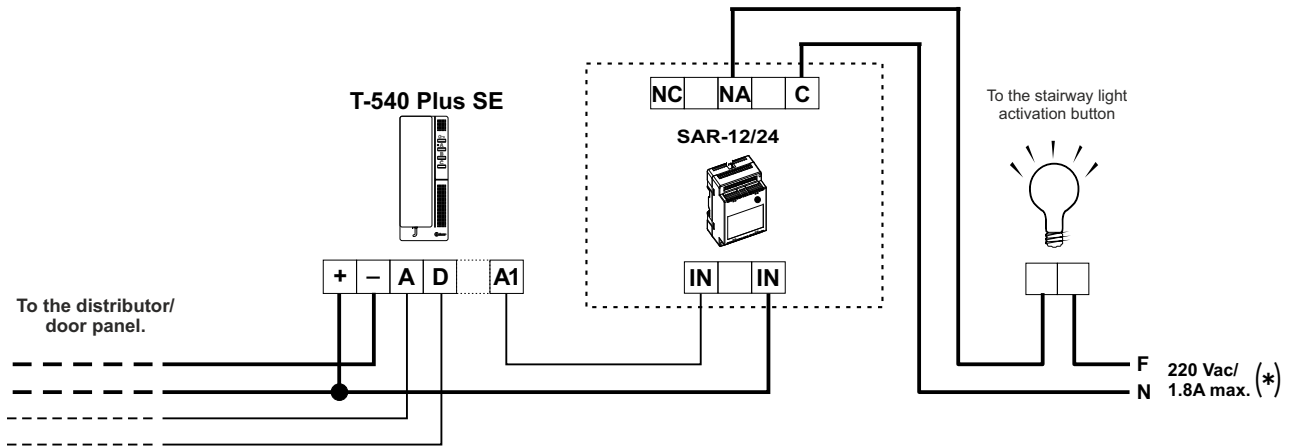

(\*) The neutral of the lighting power supply is arranged serially through the contacts of the SAR-12/24 relay and the maximum consumption of the element to be connected does not exceed 1.8A.

To activate a second door release, a TF-104 transformer is required.

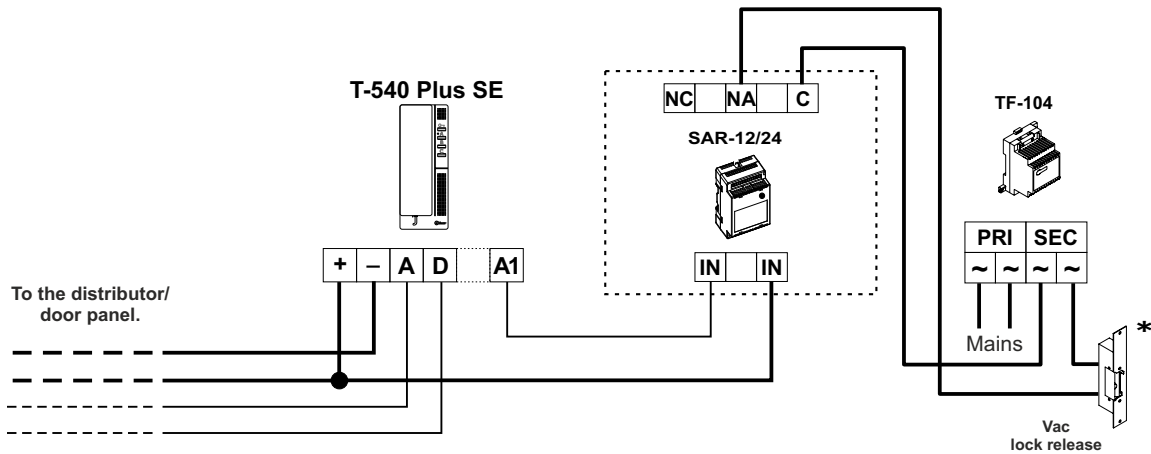

\* **Important:** Place the varistor supplied with the sound module directly onto the terminals of the lock release.

**Exterior button input for activating the door panel door release:**

This enables the door panel door release to be activated during a call or communication with the door panel. With the telephone in standby, a panic call to the guard units configured to receive such calls is made.

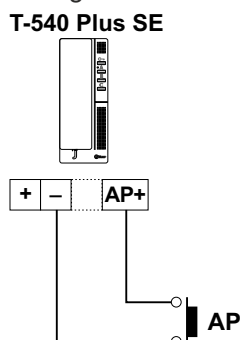

**OPTIONAL CONNECTIONS**

Continued from previous page.

**Intercom between two points in the same apartment:**

The T-540 Plus SE telephone features as standard an intercom function between two points in the same apartment. To enable this feature, the following is necessary:

- One of the telephones needs to be configured as master and the other as slave with intercom, as described on p. 7. In the case of intercom between a monitor and a telephone, it is recommended to configure the monitor as the master.
- The INT terminal of the intercom devices needs to be connected (see diagram attached).

To use the intercom function to call all of the telephones in the apartment, lift the handset and press and hold down button **B** until a confirmation tone can be heard. To call individual devices, press the button once to call the “master” telephone, twice to call “slave 1”, 3 times to call “slave 2”, 4 times to call “slave 3” and 5 times to call “slave 4”. This selective intercom call mode is only available with the T-540 Plus SE telephone. This only functions if no call or communication is in progress. A number of audible tones emitted by the handset will confirm that the call is being made or that the unit being called is in communication with the door panel. To establish communication, lift the handset of the unit being called. If a call is received from the door panel during an intercom process, the handset of the master unit will emit a number of audible tones. To establish communication with the door panel, press button **B** on the unit configured as master or press the door release button to simply open the door.

The ringtones vary depending on where the call is being made from, enabling the user to identify its origin.

**Note:** If the apartment also has T-540 Plus telephones, the T-540 Plus SE telephones must be configured as “Intercom with Plus telephones / monitors” (see p. 9). This configuration mode does not allow selective intercom calls to different telephones in the apartment; when the intercom button is pressed, all of the telephones in the apartment will receive the call.

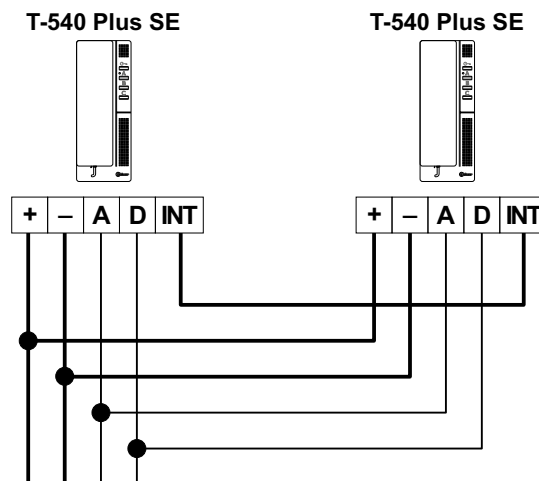

**Button for receiving calls from the apartment front door:**

The T-540 Plus SE telephone features as standard the ability to receive calls from the apartment front door. This feature precludes the need to use the bell by positioning a switch between terminals “HZ—” and “—” of the telephone.

The ringtones vary depending on where the call is being made from, enabling the user to identify its origin. If a call is made from the apartment front door during a conversation with the door panel, the handset will emit a number of tones to indicate so.

**Note:** Regardless of the volume set for the telephone's ringtones (see p. 5) and the “night mode” function, the “apartment front door call” ringtone will always sound at the highest level.

T-540 Plus SE

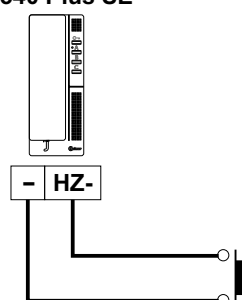

Continued overleaf

**CLEANING THE TELEPHONE**

---

- Do not use solvents, detergents or cleaning products that contain acids, vinegar or abrasive components.
- Use a soft, damp cloth (not wet) that does not leave lint behind.
- Always wipe the telephone in the same direction, from top to bottom.
- After cleaning the telephone, remove any moisture with a soft dry cloth that does not shed fibres.

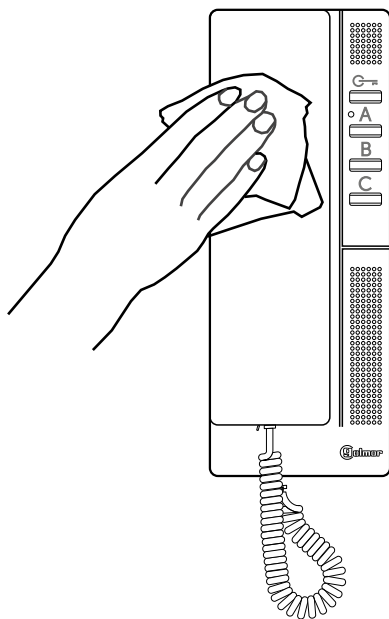

WIRING DIAGRAM

Audio door entry system:

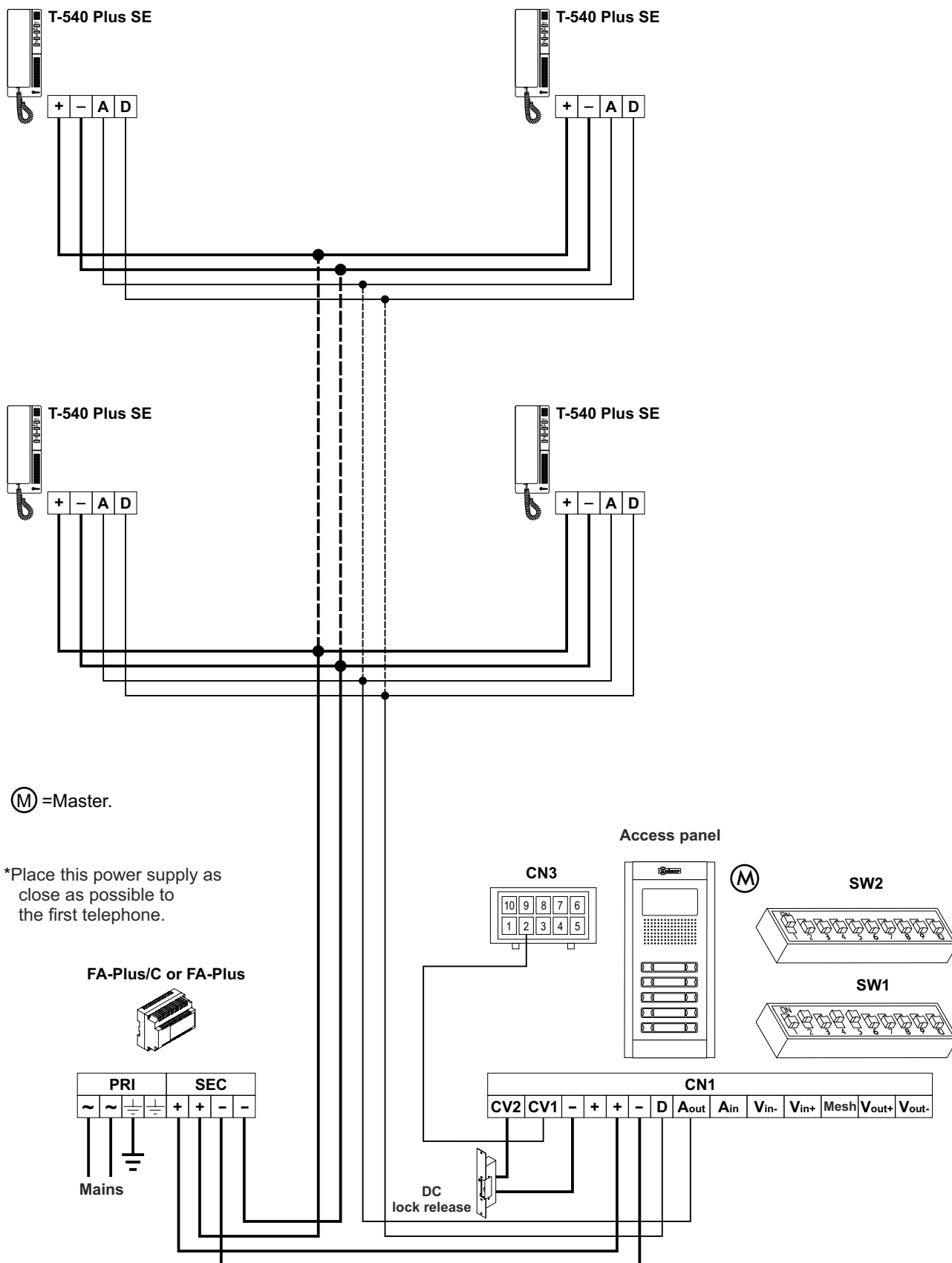

**Important:** For further information about the door panel, sections, distances, other wiring diagrams, etc., see the "T632 PLUS P/T ML" User Manual". <https://doc.golmar.es/search/manual/50122328>







golmar@golmar.es  
www.golmar.es

GOLMAR S.A.  
C/ Silici, 13  
08940- Cornellá de Llobregat  
SPAIN



Golmar se reserva el derecho a cualquier modificación sin previo aviso.  
Golmar se réserve le droit de toute modification sans préavis.  
Golmar reserves the right to make any modifications without prior notice.